

Double rod intermediate fixed trunnion

(Not according to ISO standards)

MT4

Type 06

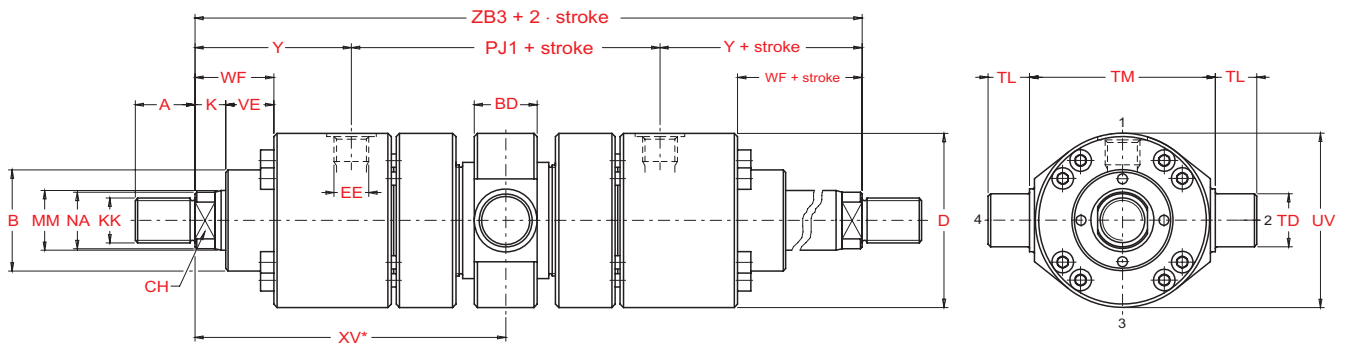

MM - Rod diameter

Bore Ø	MM Ø	A	B ^B Ø	CH	D _{max} Ø	EE (BSP)	KK (Metric)	NA Ø	K	VE	WF	BD	TD ^B Ø	TL	TM ^{h13}	UV Ø	XV min.	XV + stroke max.	Y	PJ1	ZB3	stroke min.
50	32	36	63	28	105	1/2"	M27x2	31	18	29	47	38	32	25	112	105	180	144	98	126	322	45
	32			35																		
63	40	45	75	34	122	3/4"	M33x2	38	21	32	53	48	40	32	125	122	195	160	112	134	358	45
	36			43																		
80	50	56	90	43	145	3/4"	M42x2	48	24	36	60	58	50	40	150	145	220	175	120	153	393	60
	56			54																		
100	63	63	110	53	175	1"	M48x2	60	27	41	68	73	63	50	180	175	245	185	134	165	433	80
	70			67																		
125	80	85	132	65	210	1"	M64x3	77	31	45	76	88	80	63	224	210	290	220	153	204	510	95
	90			87																		
140 ⁵⁾	90	90	145	75	255	1" 1/4	M72x3	87	31	45	76	98	90	70	265	255	330	240	181	208	570	115
	100			96																		
160	100	95	160	85	270	1" 1/4	M80x3	96	35	50	85	108	100	80	280	270	340	255	185	225	595	115
	110			106																		
180 ⁵⁾	110	105	185	95	315	1" 1/4	M90x3	106	40	55	95	118	110	90	320	315	390	270	205	250	660	150
	125			121																		
200	125	112	200	-	330	1" 1/4	M100x3	121	40	61	101	133	125	100	335	330	430	280	220	271	711	180
	140			136																		
250	160	125	250	-	410	1" 1/2	M125x4	155	42	71	113	180	160	125	425	410	505	320	260	308	828	220
	180			175																		
320	200	160	320	-	510	2"	M160x4	195	48	88	136	220	200	160	530	510	590	380	310	350	970	260
	220			214																		
400	250	200	400	-	628	2"	M200x4	242	53	110	163	270	250	200	630	628	630	340	310	355	975	340
	280			270																		

5) Bore non-compliant with ISO 6022 standard.

* Specify the dimension in case of order.

Unless otherwise specified, all dimensions are given in millimetres.



How to order a HYDROMAT H2 series cylinder compliant with ISO 6022

The HYDROMAT H2 series cylinders compliant with ISO 6022 standards are provided with an identification code which describes the construction specifications in a non-ambiguous way. To make up the code for the order, follow the code diagram set out below and insert the letters identifying the various features of the desired cylinder in the sequence given below.

Features	Description	Code
Series	To ISO 6022 standards To ISO 6022 standards for taking transducer	H2 T2
Bore	Specify bore in mm (indicate 3 figures)	-
Rod MM (diameter)	32 mm (bore 50)	I
	36 mm (bore 50)	L
	40 mm (bore 63)	O
	45 mm (bore 63)	M
	50 mm (bore 80)	N
	56 mm (bore 80)	P
	63 mm (bore 100)	Q
	70 mm (bore 100)	R
	80 mm (bore 125)	S
	90 mm (bores 125 and 140 ⁵⁾)	T
	100 mm (bores 140 ⁵⁾ and 160)	U
	110 mm (bores 160 and 180 ⁵⁾)	V
	125 mm (bores 180 ⁵⁾ and 200)	A
	140 mm (bore 200)	Z
	160 mm (bore 250)	B
	180 mm (bore 250)	X
200 mm (bore 320)	C	
220 mm (bore 320)	Y	
250 mm (bore 400)	D	
280 mm (bore 400)	W	
Stroke	Specify the stroke in mm (indicate 4 figures)	-
Rod type	Without cushioning	C
	Front cushioning	E
	Rear cushioning ⁶⁾	G
	Cushioning on both ends ⁶⁾	P
	Double rod without cushioning	S
Double rod with cushioning	T	
Special machining	Female rod threading	w
	Customised machining	z
Mounting type	Basic version (not in line to ISO 6022)	00
	Side foot (not in line to ISO 6022)	03
	Intermediate fixed trunnion (ISO MT4)	06
	Rear clevis (ISO MP3)	07
	Rear spherical bearing (ISO MP5)	08
	Front flange (ISO MF3)	13
Rear flange (ISO Mf4)	14	

Cylinder ordering code

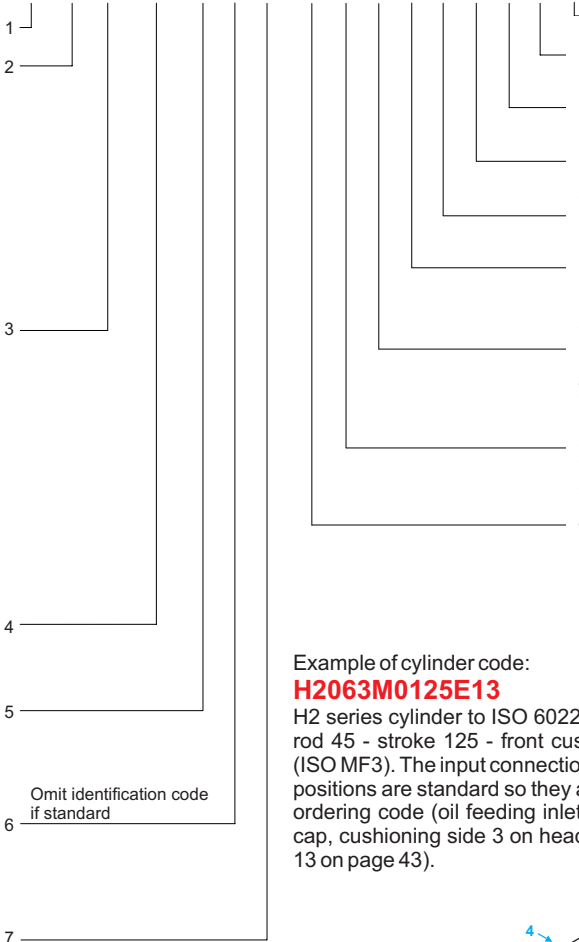
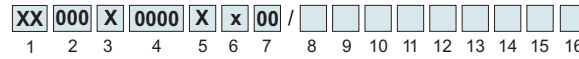

- When issuing the order for the cylinder, provide the following information:
- code identifying the model
 - quantity
 - special features (if requested) with any enclosed sketches and/or construction drawings
 - operating conditions for special uses
 - delivery date with type of priority

Code	Description	Features
D0	Specify the position of the drainage connection	Drainage connection
K00	Specify the position of the front and rear inductive sensors	Position of inductive sensors
S00	Specify the position of the front and rear air bleeds	Position of air bleeds
R00	Specify the position of the front and rear braking adjustment devices	Position of braking adjustment devices
P00	Specify the position of front and rear connections	Position of connections
-	Specify the number of spacers (multiples of 50 mm)	Spacers
T U* V** Z	Seals for water and glycol mixtures Low friction seals Seals for high temperatures and/or aggressive fluids Seals for heavy applications	Seals
D [§] E [§] F [§]	Front inductive sensor Rear inductive sensor Front and rear inductive sensor	Inductive sensors
A B C [#]	Front air bleed Rear air bleed Front and rear air bleeds	Air bleeds

- * min. working pressure 20 bar
- ** max. working temperature for T2 and H2 series cylinders fitted with inductive sensors: 70 °C
- [§] Using inductive sensors, the cylinder must be provided with cushioning (front or rear)
- [#] Compulsory for T2 series cylinders

Example of cylinder code:

H2063M0125E13

H2 series cylinder to ISO 6022 standards - bore 63 - rod 45 - stroke 125 - front cushioning - front flange (ISO MF3). The input connection and front cushioning positions are standard so they are not specified in the ordering code (oil feeding inlets side 1 on head and cap, cushioning side 3 on head as specified in Table 13 on page 43).

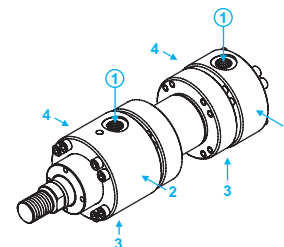

Example of cylinder code:

H2125T0800Pw06/FU P14 K22

H2 series cylinder to ISO 6022 standards - bore 125 - rod 90 - stroke 800 - cushioning on both ends - female rod threading - intermediate fixed trunnion (ISO MT4) - front and rear inductive sensor - low friction seals - position of input connections side 1 on head and side 4 on cap - position of inductive sensor side 2 on head and cap - cushioning in standard position side 3 on head and cap (see Table.13 on page 43).

5) Bore non-compliant with ISO 6022 standard
6) Not available for bores 50 and 63 of the T2 series