

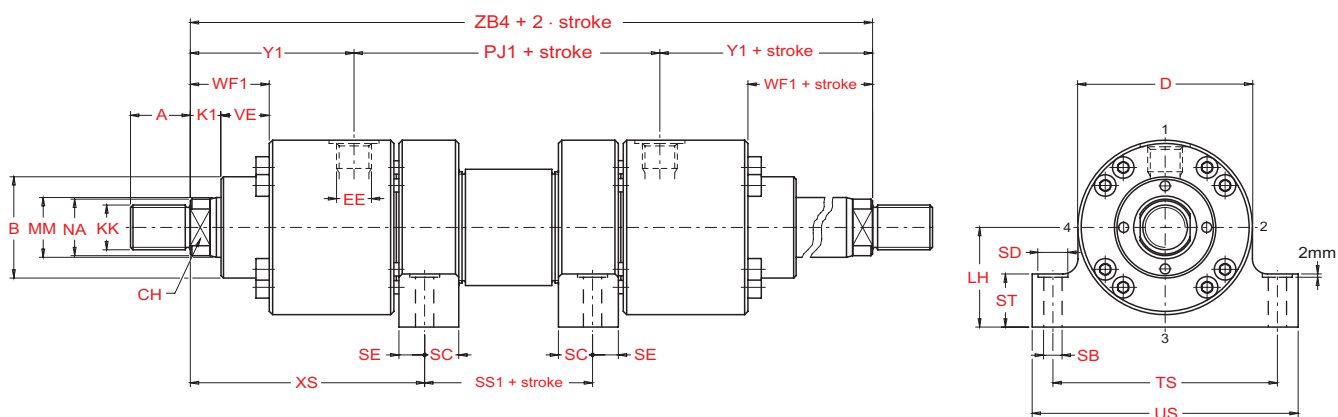

Double rod side foot
(Not according to ISO standards)

MS2

Type 03

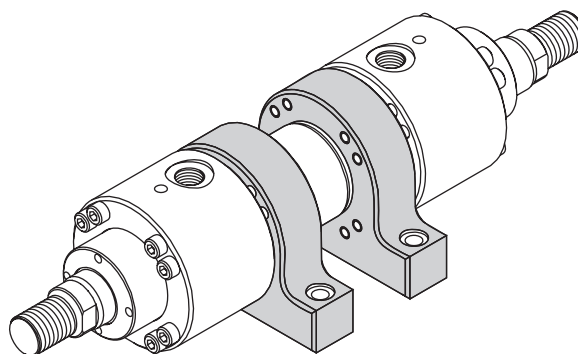

MM - Rod diameter

Bore Ø	MM Ø	A	B ⁵ Ø	CH	D _{max} Ø	EE (BSP)	KK (Metric)	NA Ø	K1	VE	WF1	LH ¹⁰	SB ^{H13} Ø	SD Ø	SC	SE	ST	TS	US	XS	Y1	SS1	PJ1	ZB4
50	32	36	63	28	105	1/2"	M27x2	31	18	29	47	60	11	18	20,5*	16	32	135	160	130	98	62	126	322
	36		32	35																				
63	40	45	75	34	122	3/4"	M33x2	38	19	32	51	68	13,5	20	24,5*	18	37	155	185	148	110	59	134	354
	45		36	43																				
80	50	56	90	43	145	3/4"	M42x2	48	24	36	60	80	17,5	26	22,5	23	42	185	225	171	120	53	153	393
	56		46	54																				
100	63	63	110	53	175	1"	M48x2	60	27	41	68	95	22	33	27,5	28	52	220	265	193	134	48	165	433
	70		60	67																				
125	80	85	132	65	210	1"	M64x3	77	31	45	76	115	26	40	30	30	62	270	325	230	153	50	204	510
	90		75	87																				
140 ⁵⁾	90	90	145	75	255	1" 1/4	M72x3	87	31	45	76	135	30	48	35,5	36	77	325	390	255	181	61	208	570
	100		85	96																				
160	100	95	160	85	270	1" 1/4	M80x3	96	38	50	88	145	33	48	37,5	38	77	340	405	266	188	70	225	601
	110		95	106																				
180 ⁵⁾	110	105	185	95	315	1" 1/4	M90x3	106	40	55	95	165	40	60	42,5	43	87	390	465	288	205	85	250	660
	125		-	121																				
200	125	112	200	-	330	1" 1/4	M100x3	121	40	61	101	170	40	60	47*	45	87	405	480	315	220	81	271	711
	140		-	136																				
250	160	125	250	-	410	1" 1/2	M125x4	155	48	71	119	215	52	76	52*	50	112	520	620	360	266	120	308	840
	180		-	175																				
320	200	160	320	-	510	2"	M160x4	195	48	88	136	260	62	110	62*	60	152	620	740	425	310	120	350	970
	220		-	214																				
400	250	200	400	-	628	2"	M200x4	242	53	110	163	320	80	120	75	75	170	760	900	455	310	91	355	975
	280		-	270																				

5) Bore non-compliant with ISO 6022 standard.

* Mounting holes offset from centre line.

Unless otherwise specified, all dimensions are given in millimetres.



How to order a HYDROMAT H2 series cylinder compliant with ISO 6022

The HYDROMAT H2 series cylinders compliant with ISO 6022 standards are provided with an identification code which describes the construction specifications in a non-ambiguous way. To make up the code for the order, follow the code diagram set out below and insert the letters identifying the various features of the desired cylinder in the sequence given below.

Features	Description	Code
Series	To ISO 6022 standards To ISO 6022 standards for taking transducer	H2 T2
Bore	Specify bore in mm (indicate 3 figures)	-
Rod MM (diameter)	32 mm (bore 50)	I
	36 mm (bore 50)	L
	40 mm (bore 63)	O
	45 mm (bore 63)	M
	50 mm (bore 80)	N
	56 mm (bore 80)	P
	63 mm (bore 100)	Q
	70 mm (bore 100)	R
	80 mm (bore 125)	S
	90 mm (bores 125 and 140 ⁵⁾)	T
	100 mm (bores 140 ⁵⁾ and 160)	U
	110 mm (bores 160 and 180 ⁵⁾)	V
	125 mm (bores 180 ⁵⁾ and 200)	A
	140 mm (bore 200)	Z
	160 mm (bore 250)	B
	180 mm (bore 250)	X
200 mm (bore 320)	C	
220 mm (bore 320)	Y	
250 mm (bore 400)	D	
280 mm (bore 400)	W	
Stroke	Specify the stroke in mm (indicate 4 figures)	-
Rod type	Without cushioning	C
	Front cushioning	E
	Rear cushioning ⁶⁾	G
	Cushioning on both ends ⁶⁾	P
	Double rod without cushioning	S
Double rod with cushioning	T	
Special machining	Female rod threading	w
	Customised machining	z
Mounting type	Basic version (not in line to ISO 6022)	00
	Side foot (not in line to ISO 6022)	03
	Intermediate fixed trunnion (ISO MT4)	06
	Rear clevis (ISO MP3)	07
	Rear spherical bearing (ISO MP5)	08
	Front flange (ISO MF3)	13
	Rear flange (ISO Mf4)	14

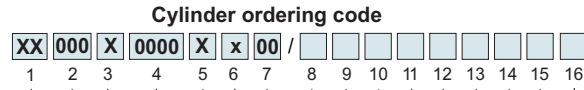

- When issuing the order for the cylinder, provide the following information:
- code identifying the model
 - quantity
 - special features (if requested) with any enclosed sketches and/or construction drawings
 - operating conditions for special uses
 - delivery date with type of priority

Code	Description	Features
D0	Specify the position of the drainage connection	Drainage connection
K00	Specify the position of the front and rear inductive sensors	Position of inductive sensors
S00	Specify the position of the front and rear air bleeds	Position of air bleeds
R00	Specify the position of the front and rear braking adjustment devices	Position of braking adjustment devices
P00	Specify the position of front and rear connections	Position of connections
-	Specify the number of spacers (multiples of 50 mm)	Spacers
T U* V** Z	Seals for water and glycol mixtures Low friction seals Seals for high temperatures and/or aggressive fluids Seals for heavy applications	Seals
D [§] E [§] F [§]	Front inductive sensor Rear inductive sensor Front and rear inductive sensor	Inductive sensors
A B C [#]	Front air bleed Rear air bleed Front and rear air bleeds	Air bleeds

- * min. working pressure 20 bar
- ** max. working temperature for T2 and H2 series cylinders fitted with inductive sensors: 70 °C
- [§] Using inductive sensors, the cylinder must be provided with cushioning (front or rear)
- [#] Compulsory for T2 series cylinders

Example of cylinder code:

H2063M0125E13

H2 series cylinder to ISO 6022 standards - bore 63 - rod 45 - stroke 125 - front cushioning - front flange (ISO MF3). The input connection and front cushioning positions are standard so they are not specified in the ordering code (oil feeding inlets side 1 on head and cap, cushioning side 3 on head as specified in Table 13 on page 43).

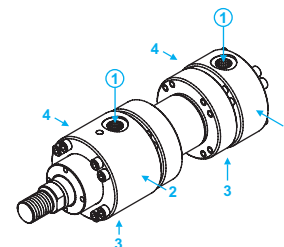

Example of cylinder code:

H2125T0800Pw06/FU P14 K22

H2 series cylinder to ISO 6022 standards - bore 125 - rod 90 - stroke 800 - cushioning on both ends - female rod threading - intermediate fixed trunnion (ISO MT4) - front and rear inductive sensor - low friction seals - position of input connections side 1 on head and side 4 on cap - position of inductive sensor side 2 on head and cap - cushioning in standard position side 3 on head and cap (see Table.13 on page 43).

5) Bore non-compliant with ISO 6022 standard
6) Not available for bores 50 and 63 of the T2 series