

Rear clevis

MP3

Type 07

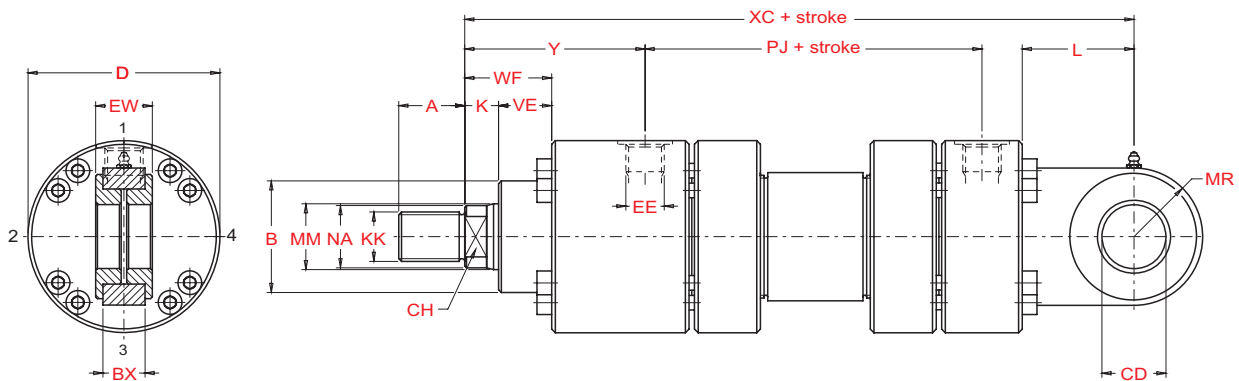

MM - Rod diameter

Bore Ø	MM Ø	A	B ⁵⁾ Ø	CH	D _{max} Ø	EE (BSP)	KK (Metric)	NA Ø	K	VE	WF	BX	CD ^{H9} Ø	EW ^{H12}	L	MR _{max}	XC	Y	PJ
50	32	36	63	28	105	1/2"	M27x2	31	18	29	47	27	32	32	61	35	305	98	120
	36			35															
63	40	45	75	34	122	3/4"	M33x2	38	21	32	53	35	40	40	74	50	348	112	133
	45			43															
80	50	56	90	43	145	3/4"	M42x2	48	24	36	60	40	50	50	90	61,5	395	120	155
	56			54															
100	63	63	110	53	175	1"	M48x2	60	27	41	68	50	63	63	102	72,5	442	134	171
	70			67															
125	80	85	132	65	210	1"	M64x3	77	31	45	76	60	80	80	124	90	520	153	205
	90			87															
140 ⁵⁾	90	90	145	75	255	1" 1/4	M72x3	87	31	45	76	65	90	90	150	113	580	181	208
	100			96															
160	100	95	160	85	270	1" 1/4	M80x3	96	35	50	85	70	100	100	150	125	617	185	235
	110			106															
180 ⁵⁾	110	105	185	95	315	1" 1/4	M90x3	106	40	55	95	80	110	110	185	147,5	690	205	250
	125			121															
200	125	112	200	-	330	1" 1/4	M100x3	121	40	61	101	102	125	125	206	160	756	220	278
	140			136															
250	160	125	250	-	410	1" 1/2	M125x4	155	42	71	113	130	160	160	251	200	903	260	325
	180			175															
320	200	160	320	-	510	2"	M160x4	195	48	88	136	162	200	200	316	250	1080	310	350
	220			214															
400	250	200	400	-	628	2"	M200x4	242	53	110	163	192	250	250	300	320	1075	310	355
	280			270															

5) Bore non-compliant with ISO 6022 standard.

All dimensions are given in millimetres.



How to order a HYDROMAT H2 series cylinder compliant with ISO 6022

The HYDROMAT H2 series cylinders compliant with ISO 6022 standards are provided with an identification code which describes the construction specifications in a non-ambiguous way. To make up the code for the order, follow the code diagram set out below and insert the letters identifying the various features of the desired cylinder in the sequence given below.

Cylinder ordering code

Features	Description	Code
Series	To ISO 6022 standards To ISO 6022 standards for taking transducer	H2 T2
Bore	Specify bore in mm (indicate 3 figures)	-
Rod MM (diameter)	32 mm (bore 50)	I
	36 mm (bore 50)	L
	40 mm (bore 63)	O
	45 mm (bore 63)	M
	50 mm (bore 80)	N
	56 mm (bore 80)	P
	63 mm (bore 100)	Q
	70 mm (bore 100)	R
	80 mm (bore 125)	S
	90 mm (bores 125 and 140 ⁵⁾)	T
	100 mm (bores 140 ⁵⁾ and 160)	U
	110 mm (bores 160 and 180 ⁵⁾)	V
	125 mm (bores 180 ⁵⁾ and 200)	A
	140 mm (bore 200)	Z
	160 mm (bore 250)	B
	180 mm (bore 250)	X
200 mm (bore 320)	C	
220 mm (bore 320)	Y	
250 mm (bore 400)	D	
280 mm (bore 400)	W	
Stroke	Specify the stroke in mm (indicate 4 figures)	-
Rod type	Without cushioning	C
	Front cushioning	E
	Rear cushioning ⁶⁾	G
	Cushioning on both ends ⁶⁾	P
	Double rod without cushioning	S
Double rod with cushioning	T	
Special machining	Female rod threading	w
	Customised machining	z
Mounting type	Basic version (not in line to ISO 6022)	00
	Side foot (not in line to ISO 6022)	03
	Intermediate fixed trunnion (ISO MT4)	06
	Rear clevis (ISO MP3)	07
	Rear spherical bearing (ISO MP5)	08
	Front flange (ISO MF3)	13
	Rear flange (ISO Mf4)	14

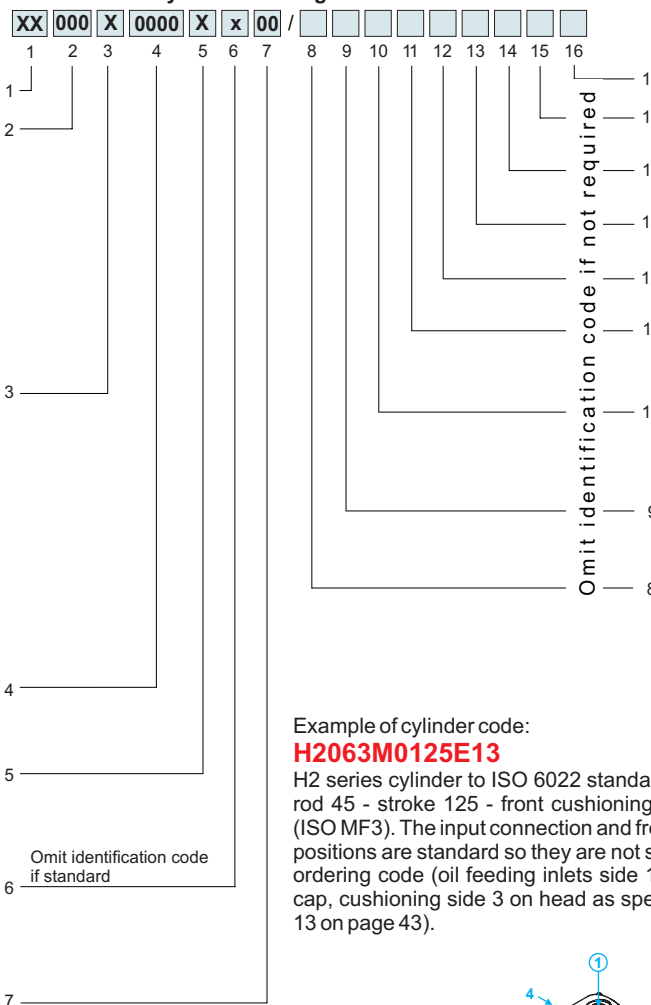

- When issuing the order for the cylinder, provide the following information:
- code identifying the model
 - quantity
 - special features (if requested) with any enclosed sketches and/or construction drawings
 - operating conditions for special uses
 - delivery date with type of priority

Code	Description	Features
D0	Specify the position of the drainage connection	Drainage connection
K00	Specify the position of the front and rear inductive sensors	Position of inductive sensors
S00	Specify the position of the front and rear air bleeds	Position of air bleeds
R00	Specify the position of the front and rear braking adjustment devices	Position of braking adjustment devices
P00	Specify the position of front and rear connections	Position of connections
-	Specify the number of spacers (multiples of 50 mm)	Spacers
T U* V** Z	Seals for water and glycol mixtures Low friction seals Seals for high temperatures and/or aggressive fluids Seals for heavy applications	Seals
D [§] E [§] F [§]	Front inductive sensor Rear inductive sensor Front and rear inductive sensor	Inductive sensors
A B C [#]	Front air bleed Rear air bleed Front and rear air bleeds	Air bleeds

- * min. working pressure 20 bar
- ** max. working temperature for T2 and H2 series cylinders fitted with inductive sensors: 70 °C
- [§] Using inductive sensors, the cylinder must be provided with cushioning (front or rear)
- [#] Compulsory for T2 series cylinders

Example of cylinder code:

H2063M0125E13

H2 series cylinder to ISO 6022 standards - bore 63 - rod 45 - stroke 125 - front cushioning - front flange (ISO MF3). The input connection and front cushioning positions are standard so they are not specified in the ordering code (oil feeding inlets side 1 on head and cap, cushioning side 3 on head as specified in Table 13 on page 43).

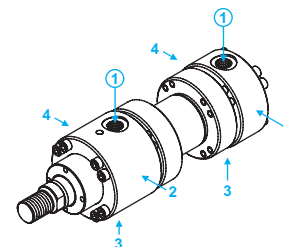

Example of cylinder code:

H2125T0800Pw06/FU P14 K22

H2 series cylinder to ISO 6022 standards - bore 125 - rod 90 - stroke 800 - cushioning on both ends - female rod threading - intermediate fixed trunnion (ISO MT4) - front and rear inductive sensor - low friction seals - position of input connections side 1 on head and side 4 on cap - position of inductive sensor side 2 on head and cap - cushioning in standard position side 3 on head and cap (see Table.13 on page 43).

5) Bore non-compliant with ISO 6022 standard
6) Not available for bores 50 and 63 of the T2 series