

## Front flange

**MF3**

Type 13

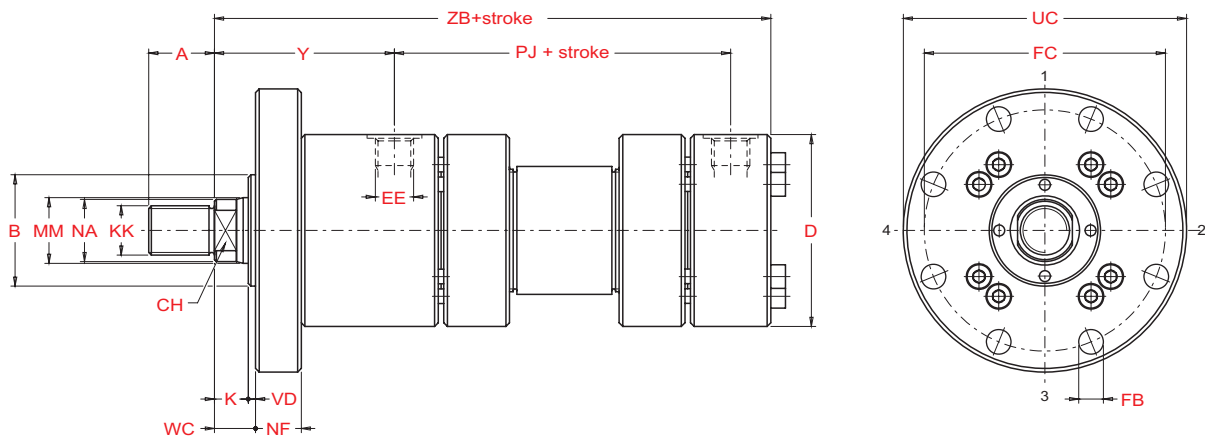

MM - Rod diameter

Bore Ø	MM Ø	A	B <sup>5)</sup> Ø	CH	D <sub>max</sub> Ø	EE (BSP)	KK (Metric)	NA Ø	K	VD	WC	NF	FB Ø	FC Ø	UC Ø	Y	PJ	ZB <sub>max</sub>
50	32	36	63	28	105	1/2"	M27x2	31	18	4	22	25	13,5 N° 8 holes	132	155	98	120	244
	36		32	35														
63	40	45	75	34	122	3/4"	M33x2	38	21	4	25	28	13,5 N° 8 holes	150	175	112	133	274
	45		36	43														
80	50	56	90	43	145	3/4"	M42x2	48	24	4	28	32	17,5 N° 8 holes	180	210	120	155	305
	56		46	54														
100	63	63	110	53	175	1"	M48x2	60	27	5	32	36	22 N° 8 holes	212	250	134	171	340
	70		60	67														
125	80	85	132	65	210	1"	M64x3	77	31	5	36	40	22 N° 8 holes	250	290	153	205	396
	90		75	87														
140 <sup>5)</sup>	90	90	145	75	255	1" 1/4	M72x3	87	31	5	36	40	26 N° 8 holes	300	340	181	208	430
	100		85	96														
160	100	95	160	85	270	1" 1/4	M80x3	96	35	5	40	45	26 N° 8 holes	315	360	185	235	467
	110		95	106														
180 <sup>5)</sup>	110	105	185	95	315	1" 1/4	M90x3	106	40	5	45	50	33 N° 8 holes	365	420	205	250	505
	125		-	121														
200	125	112	200	-	330	1" 1/4	M100x3	121	40	5	45	56	33 N° 8 holes	385	440	220	278	550
	140		-	136														
250	160	125	250	-	410	1" 1/2	M125x4	155	42	8	50	63	39 N° 8 holes	475	540	260	325	652
	180		-	175														
320	200	160	320	-	510	2"	M160x4	195	48	8	56	80	45 N° 8 holes	600	675	310	350	764
	220		-	214														
400	250	200	400	-	628	2"	M200x4	242	53	10	63	100	45 N° 12 holes	720	800	310	355	775
	280		-	270														

5) Bore non-compliant with ISO 6022 standard.

Unless otherwise specified, all dimensions are given in millimetres.



## How to order a HYDROMAT H2 series cylinder compliant with ISO 6022

The HYDROMAT H2 series cylinders compliant with ISO 6022 standards are provided with an identification code which describes the construction specifications in a non-ambiguous way. To make up the code for the order, follow the code diagram set out below and insert the letters identifying the various features of the desired cylinder in the sequence given below.

Features	Description	Code
<b>Series</b>	To ISO 6022 standards To ISO 6022 standards for taking transducer	H2 T2
<b>Bore</b>	Specify bore in mm (indicate 3 figures)	-
<b>Rod MM (diameter)</b>	32 mm (bore 50)	I
	36 mm (bore 50)	L
	40 mm (bore 63)	O
	45 mm (bore 63)	M
	50 mm (bore 80)	N
	56 mm (bore 80)	P
	63 mm (bore 100)	Q
	70 mm (bore 100)	R
	80 mm (bore 125)	S
	90 mm (bores 125 and 140 <sup>5)</sup> )	T
	100 mm (bores 140 <sup>5)</sup> and 160)	U
	110 mm (bores 160 and 180 <sup>5)</sup> )	V
	125 mm (bores 180 <sup>5)</sup> and 200)	A
	140 mm (bore 200)	Z
	160 mm (bore 250)	B
	180 mm (bore 250)	X
200 mm (bore 320)	C	
220 mm (bore 320)	Y	
250 mm (bore 400)	D	
280 mm (bore 400)	W	
<b>Stroke</b>	Specify the stroke in mm (indicate 4 figures)	-
<b>Rod type</b>	Without cushioning	C
	Front cushioning	E
	Rear cushioning <sup>6)</sup>	G
	Cushioning on both ends <sup>6)</sup>	P
	Double rod without cushioning	S
Double rod with cushioning	T	
<b>Special machining</b>	Female rod threading	w
	Customised machining	z
<b>Mounting type</b>	Basic version (not in line to ISO 6022)	00
	Side foot (not in line to ISO 6022)	03
	Intermediate fixed trunnion (ISO MT4)	06
	Rear clevis (ISO MP3)	07
	Rear spherical bearing (ISO MP5)	08
	Front flange (ISO MF3)	13
Rear flange (ISO Mf4)	14	

### Cylinder ordering code

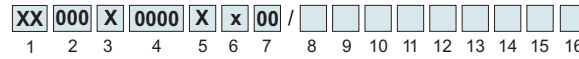

- When issuing the order for the cylinder, provide the following information:
- code identifying the model
  - quantity
  - special features (if requested) with any enclosed sketches and/or construction drawings
  - operating conditions for special uses
  - delivery date with type of priority

Code	Description	Features
D0	Specify the position of the drainage connection	Drainage connection
K00	Specify the position of the front and rear inductive sensors	Position of inductive sensors
S00	Specify the position of the front and rear air bleeds	Position of air bleeds
R00	Specify the position of the front and rear braking adjustment devices	Position of braking adjustment devices
P00	Specify the position of front and rear connections	Position of connections
-	Specify the number of spacers (multiples of 50 mm)	Spacers
T U* V** Z	Seals for water and glycol mixtures Low friction seals Seals for high temperatures and/or aggressive fluids Seals for heavy applications	Seals
D <sup>§</sup> E <sup>§</sup> F <sup>§</sup>	Front inductive sensor Rear inductive sensor Front and rear inductive sensor	Inductive sensors
A B C <sup>#</sup>	Front air bleed Rear air bleed Front and rear air bleeds	Air bleeds

- \* min. working pressure 20 bar
- \*\* max. working temperature for T2 and H2 series cylinders fitted with inductive sensors: 70 °C
- <sup>§</sup> Using inductive sensors, the cylinder must be provided with cushioning (front or rear)
- <sup>#</sup> Compulsory for T2 series cylinders

Example of cylinder code:

**H2063M0125E13**

H2 series cylinder to ISO 6022 standards - bore 63 - rod 45 - stroke 125 - front cushioning - front flange (ISO MF3). The input connection and front cushioning positions are standard so they are not specified in the ordering code (oil feeding inlets side 1 on head and cap, cushioning side 3 on head as specified in Table 13 on page 43).

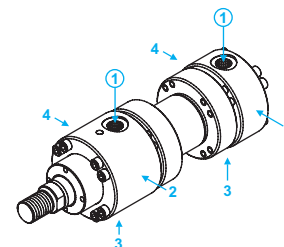

Example of cylinder code:

**H2125T0800Pw06/FU P14 K22**

H2 series cylinder to ISO 6022 standards - bore 125 - rod 90 - stroke 800 - cushioning on both ends - female rod threading - intermediate fixed trunnion (ISO MT4) - front and rear inductive sensor - low friction seals - position of input connections side 1 on head and side 4 on cap - position of inductive sensor side 2 on head and cap - cushioning in standard position side 3 on head and cap (see Table.13 on page 43).

5) Bore non-compliant with ISO 6022 standard  
6) Not available for bores 50 and 63 of the T2 series