

Rectangular front flange

(Not according ISO standard)

Type O1

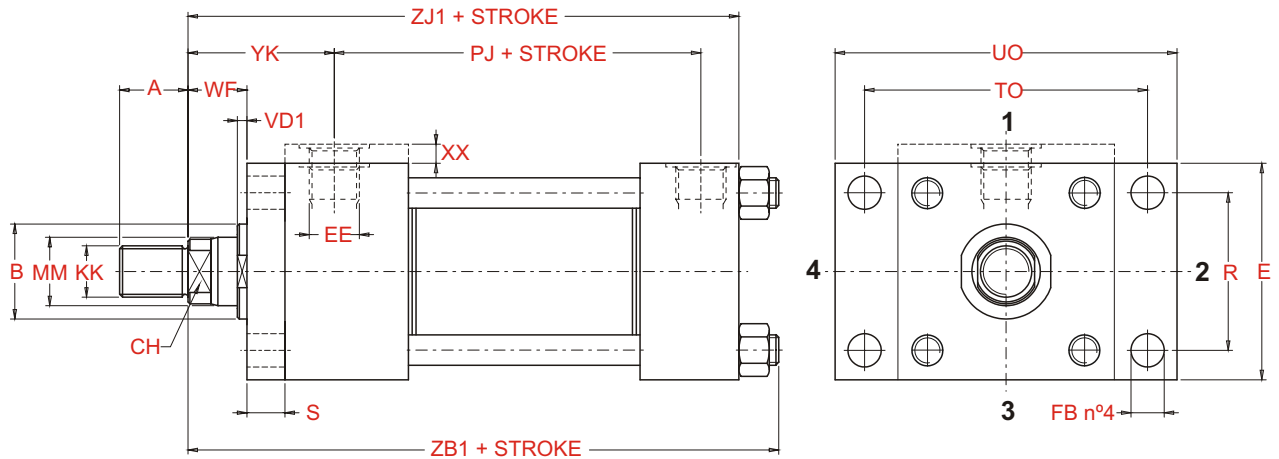

MM - Rod diameter

Bore Ø	MM Ø	A	B	CH	XX	E	EE	FB	KK	PJ	R	S	TO	UO	VD1	WF	YK	ZB1	ZJ1
		max	f9				(BSP)	H13	(Metric)	± 1,25	JS13	max	JS13	max		± 2	± 2	max	± 1
25	12	14	24	9	5	40 ±1,5	1/4"	5,5	M 10x1,25	54	27	10	51	64	6	25	60	131	124
	18	18	30	14					M14x1,5										
32	14	16	26	11					M12x1,25						12				
	18	18	30	14	5	45 ±1,5	1/4"	6,6	M14x1,5	57	33	10	58	70	6	35	70	147	138
	22	22	34	17					M16x1,5						12				
40	18	18	30	14					M14x1,5						4				
	22	22	34	17	-	60 ±1,5	3/8"	11	M16x1,5	74	41	12	87	110	10	35	74	178	165
	28	28	42	22					M20x1,5						8				
50	22	22	34	17					M16x1,5						7				
	28	28	42	22	-	75 ±1,5	1/2"	13,5	M20x1,5	76	52	15	105	130	7	41	83	191	174
	36	36	50	30					M27x2						10				
63	28	28	42	22					M20x1,5						4				
	36	36	50	30	-	90 ±1,5	1/2"	13,5	M27x2	80	65	18	117	140	7	48	89	203	186
	45	45	60	36					M33x2						11				
80	36	36	50	30					M27x2						5				
	45	45	60	36	-	114 ±1,5	3/4"	17,5	M33x2	93	83	20	149	180	9	51	97	232	210
	56	56	72	50					M42x2						9				
100	45	45	60	36					M33x2						4				
	56	56	72	50	-	126 ±2	3/4"	17,5	M42x2	101	97	25	162	190	4	57	107	250	228
	70	63	88	60					M48x2						7				
125	56	56	72	50					M42x2						4				
	70	63	88	60	-	164 ±2	1"	22	M48x2	117	126	25*	208	240	7	57	111	285	257
	90	85	108	75					M64x3						6				
160	70	63	88	60					M48x2						4				
	90	85	108	80	-	198 ±2	1"	26	M64x3	130	155	27**	253	300	5	57	113	306	272
	110	95	133	100					M80x3										
200	90	85	108	80					M64x3						5	57	125	363	326
	110	95	133	100	-	240 ±2	1" 1/4	33	M80x3	165	190	27***	300	350	5	57	125	363	326
	140	112	163	130					M100x3										

Unless otherwise specified, all dimensions are given in millimetres.



How to order a HYDROMAT A3 series cylinder compliant with ISO 6020/2

The HYDROMAT A3 series cylinders compliant with ISO 6020/2 standards are provided with an identification code which describes the construction specifications in a non-ambiguous way. To make up the code for the order, follow the code diagram set out below and insert the letters identifying the various features of the desired cylinder in the sequence given below.

Features	Description	Code
Series	To ISO 6020/2 standards To ISO 6020/2 standards with magnetic sensor ¹⁾ To ISO 6020/2 stand. for taking lin. transducers ²⁾	A3 M3 T3
Bore	Specify bore in mm (indicate 3 figures)	-
Rod MM (diameter)	12 mm (bore 25) 14 mm (bore 32) 18 mm (bore 25, 32 and 40) 22 mm (bore 32, 40 and 50) 28 mm (bore 40, 50 and 63) 36 mm (bore 50, 63 and 80) 45 mm (bore 63, 80 and 100) 56 mm (bore 80, 100 and 125) 70 mm (bore 100, 125 and 160) 90 mm (bore 125, 160 and 200) 110 mm (bore 160 and 200) 140 mm (bore 200)	A B D F H L M P R T V Z
Stroke	Specify the stroke in mm (indicate 4 figures)	-
Rod type	Without cushioning Front cushioning Rear cushioning Cushioning on both ends Double rod without cushioning Double rod with cushioning	C E G P S T
Special machining of rod end	Light male thread Female thread Light female thread Customised thread	x w y z
Mounting type	Basic version (not in line to ISO 6020/2) Rectangular front flange (not in line to ISO 6020/2) Rectangular rear flange (not in line to ISO 6020/2) Side foot (ISO MS2) Head trunnion (ISO MT1) Cap trunnion (ISO MT2) Intermediate fixed trunnion (ISO MT4) Rear clevis (ISO MP3) Rear spherical bearing (ISO MP5) Cap fixed clevis (IS MP1) Extended front tie rods (ISO MX3) Extended rear tie rods (ISO MX2) Extended on both ends tie rods (ISO MX1) Head flange (ISO ME5) Cap flange (ISO ME6) Front screwed tapped holes (ISO MX5) Rear screwed tapped holes (ISO MX6)	00 01 02 03 04 05 06 07 08 09 10 11 12 13 14 30 31

Cylinder ordering code

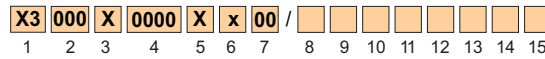

Omit if is not look for

Example of cylinder code:

A3063H0125E02

A3 = series differential Cylinder compliant with ISO 6020/2

063 = bore 63

H = rod 28

125 = stroke 125

E = front cushioning

02 = rectangular rear flange (not compliant with ISO standards).

The positions of the inlet connections and front cushion are standard so they are not specified in the order code (oil feeding inlets side 1 on head and cap - cushion side 3 on head

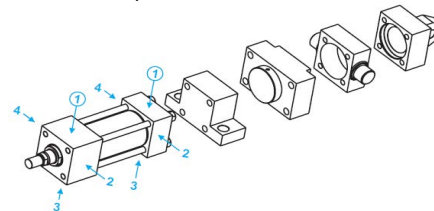

When issuing the order for the cylinder, provide the following information:

- code identifying the model
- quantity
- special features (if requested) with any enclosed sketches and/or construction drawings
- operating conditions for special uses
- delivery date with type of priority

Code	Description	Features
K00	Specify the position of the front and rear inductive sensors	Position of inductive sensors
S00	Specify the position of the front and rear air bleeds	Position of air bleeds
R00	Specify the position of the front and rear braking adjustment devices	Position of braking adjustment devices
P00	Specify the position of front and rear connections	Position of connections
-	Specify the number of spacers (multiples of 50 mm)	Spacers
T U ³⁾ V ⁴⁾	Seals for water and glycol mixtures Low friction seals Seals for high temperatures and/or aggressive fluids	Seals
D ⁵⁾ E ⁵⁾ F ⁵⁾	Front inductive sensor Rear inductive sensor Front and rear inductive sensor	Inductive sensors
A B C ⁶⁾	Front air bleed Rear air bleed Front and rear air bleeds	Air bleed

³⁾ Minimum working pressure: 20 bar

⁴⁾ Max. working temp. for M3, T3 and A3 series cylinders fitted with inductive sensors: 70 °C

Using inductive sensors, the cylinder must be provided with cushioning (front or rear)

⁵⁾ Not available for bores 25 and 32, see page 42

⁶⁾ Compulsory for T3 series cylinders

Example of cylinder code:

A3100M0400PW10/FUP14K22

A3 = series differential Cylinder compliant with ISO 6020/2 standards

100 = bore 100, **M** = rod 45, **0400** = stroke 400,

P = cushioning on both ends,

W = female thread rod ends

10 = extended front tie rods (ISO Mx3)

F = front and rear inductive sensor, **U** = low friction seals

P = position of incoming connections side 1 on the head and side 4 on the cap

K = position of inductive sensor side 2 on head and 2 on cap

- standard cushion position side 3 on head and cap (see Table 19 on page 64).

¹⁾ Not available for bores 160 and 200, see page 40

²⁾ Not available for bores 25, 32, 40 (rods 18 and 22), 50 (rod 22), see page 43