

Cap trunnion

**MT2**

Type 05

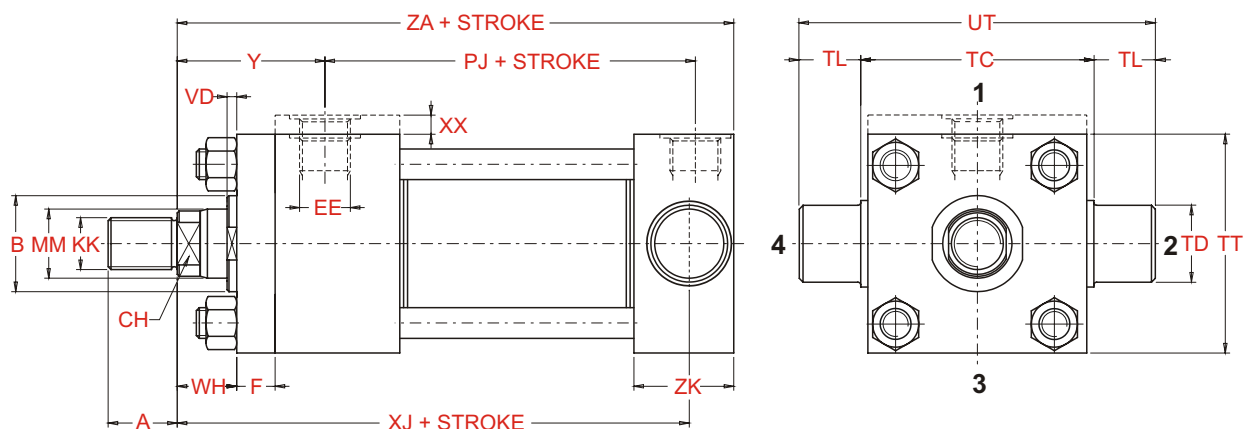

MM - Rod diameter

Bore Ø	MM Ø	A max	B f9	CH	XX	F	EE (BSP)	KK (Metric)	PJ ± 1,25	TC h14	TD f8	TL	TT	UT h15	VD	XJ ± 1,25	WH ± 2	Y ± 2	ZA ± 1	ZK
25	12	14	24	9	5	10	1/4"	M10x1,25	54	38	12	10	38	58	6	101	15	50	114	35
	18	18	30	14				M14x1,5												
32	14	16	26	11	5	10	1/4"	M12x1,25	57	44	16	12	44	68	12	115	25	60	128	36
	18	18	30	14				M14x1,5							6					
	22	22	34	17				M16x1,5							12					
40	18	18	30	14	-	10	3/8"	M14x1,5	74	63	20	16	60	95	6	134	25	62	153	45
	22	22	34	17				M16x1,5							12					
	28	28	42	22				M20x1,5							10					
50	22	22	34	17	-	15	1/2"	M16x1,5	76	76	25	20	75	116	7	140	26	68	159	45
	28	28	42	22				M20x1,5							7					
	36	36	50	30				M27x2							10					
63	28	28	42	22	-	15	1/2"	M20x1,5	80	89	32	25	88	139	7	149	33	71	168	45
	36	36	50	30				M27x2							10					
	45	45	60	36				M33x2							14					
80	36	36	50	30	-	20	3/4"	M27x2	93	114	40	32	114	178	5	168	31	77	190	52
	45	45	60	36				M33x2							9					
	56	56	72	50				M42x2							9					
100	45	45	60	36	-	22	3/4"	M33x2	101	127	50	40	126	207	7	187	35	82	216	68
	56	56	72	50				M42x2							7					
	70	63	88	60				M48x2							10					
125	56	56	72	50	-	22	1"	M42x2	117	165	63	50	164	265	6	209	35	86	246	85
	70	63	88	60				M48x2							10					
	90	85	108	75				M64x3							10					
160	70	63	88	60	-	25	1"	M48x2	130	203	80	63	198	329	7	230	32	86	277	95
	90	85	108	80				M64x3							7					
	110	95	133	100				M80x3							7					
200	90	85	108	80	-	25	1" 1/4	M64x3	165	241	100	80	240	401	7	276	32	98	334	115
	110	95	133	100				M80x3							7					
	140	112	163	130				M100x3							7					



## How to order a HYDROMAT A3 series cylinder compliant with ISO 6020/2

The HYDROMAT A3 series cylinders compliant with ISO 6020/2 standards are provided with an identification code which describes the construction specifications in a non-ambiguous way. To make up the code for the order, follow the code diagram set out below and insert the letters identifying the various features of the desired cylinder in the sequence given below.

Features	Description	Code
<b>Series</b>	To ISO 6020/2 standards To ISO 6020/2 standards with magnetic sensor <sup>1)</sup> To ISO 6020/2 stand. for taking lin. transducers <sup>2)</sup>	A3 M3 T3
<b>Bore</b>	Specify bore in mm (indicate 3 figures)	-
<b>Rod MM (diameter)</b>	12 mm (bore 25) 14 mm (bore 32) 18 mm (bore 25, 32 and 40) 22 mm (bore 32, 40 and 50) 28 mm (bore 40, 50 and 63) 36 mm (bore 50, 63 and 80) 45 mm (bore 63, 80 and 100) 56 mm (bore 80, 100 and 125) 70 mm (bore 100, 125 and 160) 90 mm (bore 125, 160 and 200) 110 mm (bore 160 and 200) 140 mm (bore 200)	A B D F H L M P R T V Z
<b>Stroke</b>	Specify the stroke in mm (indicate 4 figures)	-
<b>Rod type</b>	Without cushioning Front cushioning Rear cushioning Cushioning on both ends Double rod without cushioning Double rod with cushioning	C E G P S T
<b>Special machining of rod end</b>	Light male thread Female thread Light female thread Customised thread	x w y z
<b>Mounting type</b>	Basic version (not in line to ISO 6020/2) Rectangular front flange (not in line to ISO 6020/2) Rectangular rear flange (not in line to ISO 6020/2) Side foot (ISO MS2) Head trunnion (ISO MT1) Cap trunnion (ISO MT2) Intermediate fixed trunnion (ISO MT4) Rear clevis (ISO MP3) Rear spherical bearing (ISO MP5) Cap fixed clevis (IS MP1) Extended front tie rods (ISO MX3) Extended rear tie rods (ISO MX2) Extended on both ends tie rods (ISO MX1) Head flange (ISO ME5) Cap flange (ISO ME6) Front screwed tapped holes (ISO MX5) Rear screwed tapped holes (ISO MX6)	00 01 02 03 04 05 06 07 08 09 10 11 12 13 14 30 31

### Cylinder ordering code

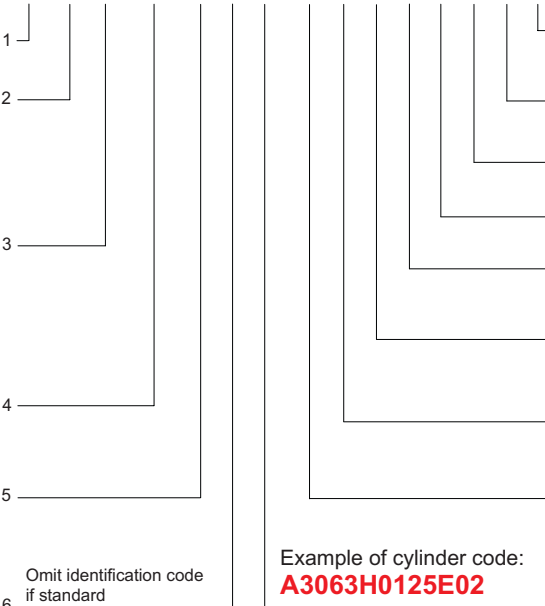
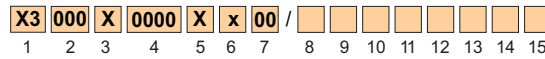

Omit if is not look for

Example of cylinder code:  
**A3063H0125E02**

**A3** = series differential Cylinder compliant with ISO 6020/2  
**063** = bore 63  
**H** = rod 28  
**125** = stroke 125  
**E** = front cushioning  
**02** = rectangular rear flange (not compliant with ISO standards).

The positions of the inlet connections and front cushion are standard so they are not specified in the order code (oil feeding inlets side 1 on head and cap - cushion side 3 on head

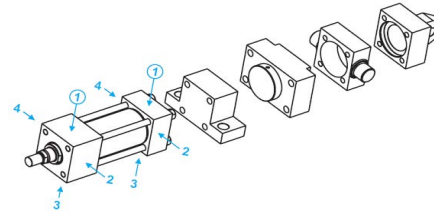

When issuing the order for the cylinder, provide the following information:

- code identifying the model
- quantity
- special features (if requested) with any enclosed sketches and/or construction drawings
- operating conditions for special uses
- delivery date with type of priority

Code	Description	Features
K00	Specify the position of the front and rear inductive sensors	<b>Position of inductive sensors</b>
S00	Specify the position of the front and rear air bleeds	<b>Position of air bleeds</b>
R00	Specify the position of the front and rear braking adjustment devices	<b>Position of braking adjustment devices</b>
P00	Specify the position of front and rear connections	<b>Position of connections</b>
-	Specify the number of spacers (multiples of 50 mm)	<b>Spacers</b>
T U <sup>3)</sup> V <sup>4)</sup>	Seals for water and glycol mixtures Low friction seals Seals for high temperatures and/or aggressive fluids	<b>Seals</b>
D <sup>5)</sup> E <sup>5)</sup> F <sup>5)</sup>	Front inductive sensor Rear inductive sensor Front and rear inductive sensor	<b>Inductive sensors</b>
A B C <sup>6)</sup>	Front air bleed Rear air bleed Front and rear air bleeds	<b>Air bleed</b>

- <sup>3)</sup> Minimum working pressure: 20 bar  
<sup>4)</sup> Max. working temp. for M3, T3 and A3 series cylinders fitted with inductive sensors: 70 °C  
<sup>5)</sup> Using inductive sensors, the cylinder must be provided with cushioning (front or rear)  
<sup>6)</sup> Not available for bores 25 and 32, see page 42  
<sup>6)</sup> Compulsory for T3 series cylinders

Example of cylinder code:  
**A3100M0400PW10/FUP14K22**

**A3** = series differential Cylinder compliant with ISO 6020/2 standards  
**100** = bore 100, **M** = rod 45, **0400** = stroke 400,  
**P** = cushioning on both ends,  
**W** = female thread rod ends  
**10** = extended front tie rods (ISO Mx3)  
**F** = front and rear inductive sensor, **U** = low friction seals  
**P** = position of incoming connections side 1 on the head and side 4 on the cap  
**K** = position of inductive sensor side 2 on head and 2 on cap

- standard cushion position side 3 on head and cap (see Table 19 on page 64).

<sup>1)</sup> Not available for bores 160 and 200, see page 40

<sup>2)</sup> Not available for bores 25, 32, 40 (rods 18 and 22), 50 (rod 22), see page 43