

Side foot

**MS2**

Type O3

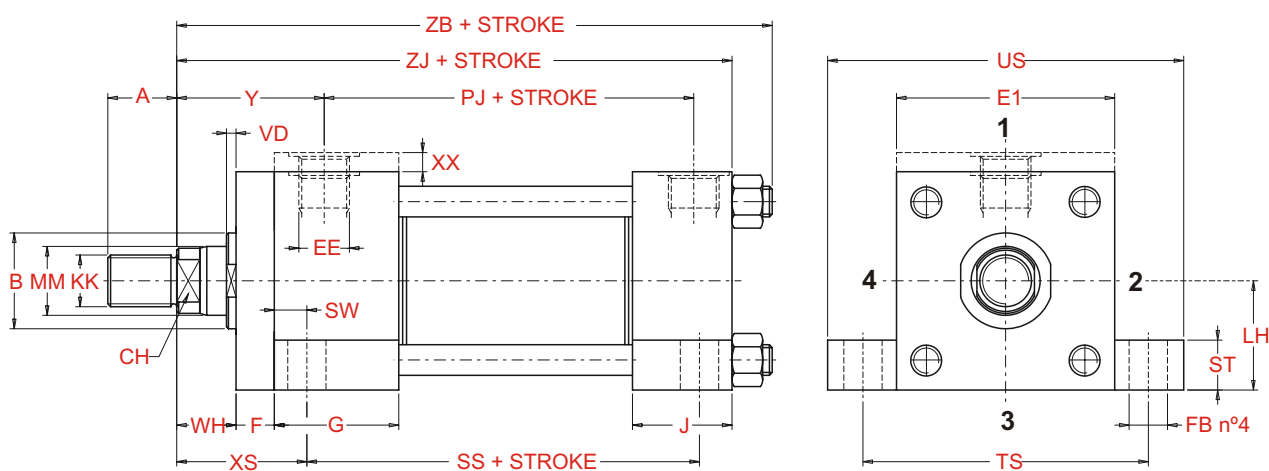

MM - Rod diameter

Bore Ø	MM Ø	A	B	CH	XX	E1	EE	F	G	J	KK	LH	PJ	SB	SS	ST	SW	VD	TS	US	XS	WH	Y	ZB	ZJ
		max	f9				(BSP)				(Metric)	h10	± 1,25	H13	± 1,25			JS13	± 2	± 2	± 2	± 2	± 1	± 1	
25	12	14	24	9	5	38	1/4"	10	45	35	M10x1,25	19	54	6,6	73	8,5	8	6	54	70	33	15	50	121	114
	18	18	30	14							M14x1,5														
32	14	16	26	11							M12x1,25						12		63	84	45	25	60	137	128
	18	18	30	14	5	44	1/4"	10	45	36	M14x1,5	22	57	9	73	13	10	6							
	22	22	34	17							M16x1,5							12							
40	18	18	30	14							M14x1,5						6								
	22	22	34	17	-	60	3/8"	10	55	45	M16x1,5	31	74	11	98	13	10	12	83	102	45	25	62	166	153
	28	28	42	22							M20x1,5						10								
50	22	22	34	17							M16x1,5						7								
	28	28	42	22	-	75	1/2"	15	55	45	M20x1,5	37	76	14	92	19	13	7	102	126	54	26	68	176	159
	36	36	50	30							M27x2						10								
63	28	28	42	22							M20x1,5						7								
	36	36	50	30	-	90	1/2"	15	55	45	M27x2	44	80	18	86	26	17	10	124	160	65	33	71	185	168
	45	45	60	36							M33x2						14								
80	36	36	50	30							M27x2						5								
	45	45	60	36	-	114	3/4"	20	65	52	M33x2	57	93	18	105	26	17	9	149	186	68	31	77	212	190
	56	56	72	50							M42x2						9								
100	45	45	60	36							M33x2						7								
	56	56	72	50	-	126	3/4"	22	69	55	M42x2	63	101	26	102	32	22	7	172	216	79	35	82	225	203
	70	63	88	60							M48x2						10								
125	56	56	72	50							M42x2						6								
	70	63	88	60	-	164	1"	22	78	71	M48x2	82	117	26	131	32	22	10	210	254	79	35	86	260	232
	90	85	108	75							M64x3						10								
160	70	63	88	60							M48x2						7								
	90	85	108	80	-	198	1"	25	86	63	M64x3	101	130	33	130	38	29	7	260	318	86	32	86	279	245
	110	95	133	100							M80x3														
200	90	85	108	80							M64x3														
	110	95	133	100	-	240	1" 1/4	25	103	80	M80x3	122	165	39	172	44	35	7	311	380	92	32	98	336	299
	140	112	163	130							M100x3														



## How to order a HYDROMAT A3 series cylinder compliant with ISO 6020/2

The HYDROMAT A3 series cylinders compliant with ISO 6020/2 standards are provided with an identification code which describes the construction specifications in a non-ambiguous way. To make up the code for the order, follow the code diagram set out below and insert the letters identifying the various features of the desired cylinder in the sequence given below.

Features	Description	Code
<b>Series</b>	To ISO 6020/2 standards To ISO 6020/2 standards with magnetic sensor <sup>1)</sup> To ISO 6020/2 stand. for taking lin. transducers <sup>2)</sup>	A3 M3 T3
<b>Bore</b>	Specify bore in mm (indicate 3 figures)	-
<b>Rod MM (diameter)</b>	12 mm (bore 25) 14 mm (bore 32) 18 mm (bore 25, 32 and 40) 22 mm (bore 32, 40 and 50) 28 mm (bore 40, 50 and 63) 36 mm (bore 50, 63 and 80) 45 mm (bore 63, 80 and 100) 56 mm (bore 80, 100 and 125) 70 mm (bore 100, 125 and 160) 90 mm (bore 125, 160 and 200) 110 mm (bore 160 and 200) 140 mm (bore 200)	A B D F H L M P R T V Z
<b>Stroke</b>	Specify the stroke in mm (indicate 4 figures)	-
<b>Rod type</b>	Without cushioning Front cushioning Rear cushioning Cushioning on both ends Double rod without cushioning Double rod with cushioning	C E G P S T
<b>Special machining of rod end</b>	Light male thread Female thread Light female thread Customised thread	x w y z
<b>Mounting type</b>	Basic version (not in line to ISO 6020/2) Rectangular front flange (not in line to ISO 6020/2) Rectangular rear flange (not in line to ISO 6020/2) Side foot (ISO MS2) Head trunnion (ISO MT1) Cap trunnion (ISO MT2) Intermediate fixed trunnion (ISO MT4) Rear clevis (ISO MP3) Rear spherical bearing (ISO MP5) Cap fixed clevis (IS MP1) Extended front tie rods (ISO MX3) Extended rear tie rods (ISO MX2) Extended on both ends tie rods (ISO MX1) Head flange (ISO ME5) Cap flange (ISO ME6) Front screwed tapped holes (ISO MX5) Rear screwed tapped holes (ISO MX6)	00 01 02 03 04 05 06 07 08 09 10 11 12 13 14 30 31

### Cylinder ordering code

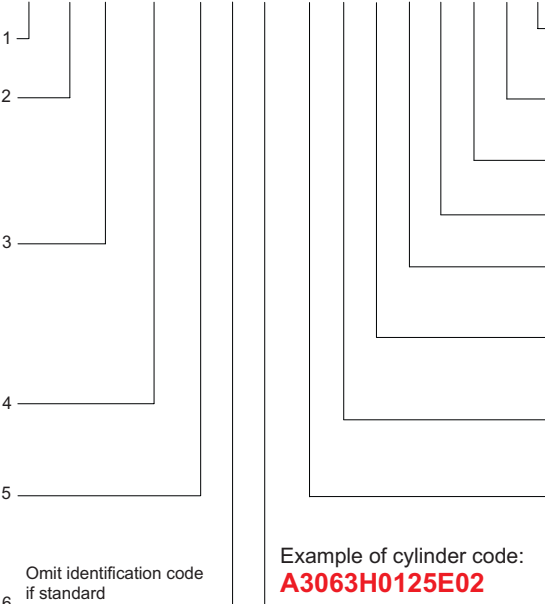
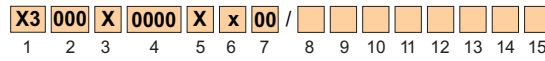

Omit if is not look for

Example of cylinder code:  
**A3063H0125E02**

**A3** = series differential Cylinder compliant with ISO 6020/2  
**063** = bore 63  
**H** = rod 28  
**125** = stroke 125  
**E** = front cushioning  
**02** = rectangular rear flange (not compliant with ISO standards).

The positions of the inlet connections and front cushion are standard so they are not specified in the order code (oil feeding inlets side 1 on head and cap - cushion side 3 on head

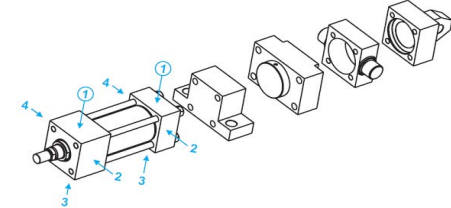

When issuing the order for the cylinder, provide the following information:

- code identifying the model
- quantity
- special features (if requested) with any enclosed sketches and/or construction drawings
- operating conditions for special uses
- delivery date with type of priority

Code	Description	Features
K00	Specify the position of the front and rear inductive sensors	<b>Position of inductive sensors</b>
S00	Specify the position of the front and rear air bleeds	<b>Position of air bleeds</b>
R00	Specify the position of the front and rear braking adjustment devices	<b>Position of braking adjustment devices</b>
P00	Specify the position of front and rear connections	<b>Position of connections</b>
-	Specify the number of spacers (multiples of 50 mm)	<b>Spacers</b>
T U <sup>3)</sup> V <sup>4)</sup>	Seals for water and glycol mixtures Low friction seals Seals for high temperatures and/or aggressive fluids	<b>Seals</b>
D <sup>5)</sup> E <sup>5)</sup> F <sup>5)</sup>	Front inductive sensor Rear inductive sensor Front and rear inductive sensor	<b>Inductive sensors</b>
A B C <sup>6)</sup>	Front air bleed Rear air bleed Front and rear air bleeds	<b>Air bleed</b>

- <sup>3)</sup> Minimum working pressure: 20 bar  
<sup>4)</sup> Max. working temp. for M3, T3 and A3 series cylinders fitted with inductive sensors: 70 °C  
<sup>5)</sup> Using inductive sensors, the cylinder must be provided with cushioning (front or rear)  
<sup>6)</sup> Not available for bores 25 and 32, see page 42  
<sup>6)</sup> Compulsory for T3 series cylinders

Example of cylinder code:  
**A3100M0400PW10/FUP14K22**

**A3** = series differential Cylinder compliant with ISO 6020/2 standards  
**100** = bore 100, **M** = rod 45, **0400** = stroke 400,  
**P** = cushioning on both ends,  
**W** = female thread rod ends  
**10** = extended front tie rods (ISO Mx3)  
**F** = front and rear inductive sensor, **U** = low friction seals  
**P** = position of incoming connections side 1 on the head and side 4 on the cap  
**K** = position of inductive sensor side 2 on head and 2 on cap

- standard cushion position side 3 on head and cap (see Table 19 on page 64).

<sup>1)</sup> Not available for bores 160 and 200, see page 40

<sup>2)</sup> Not available for bores 25, 32, 40 (rods 18 and 22), 50 (rod 22), see page 43