

Double rod intermediate fixed trunnion

**MT4**

Type O6

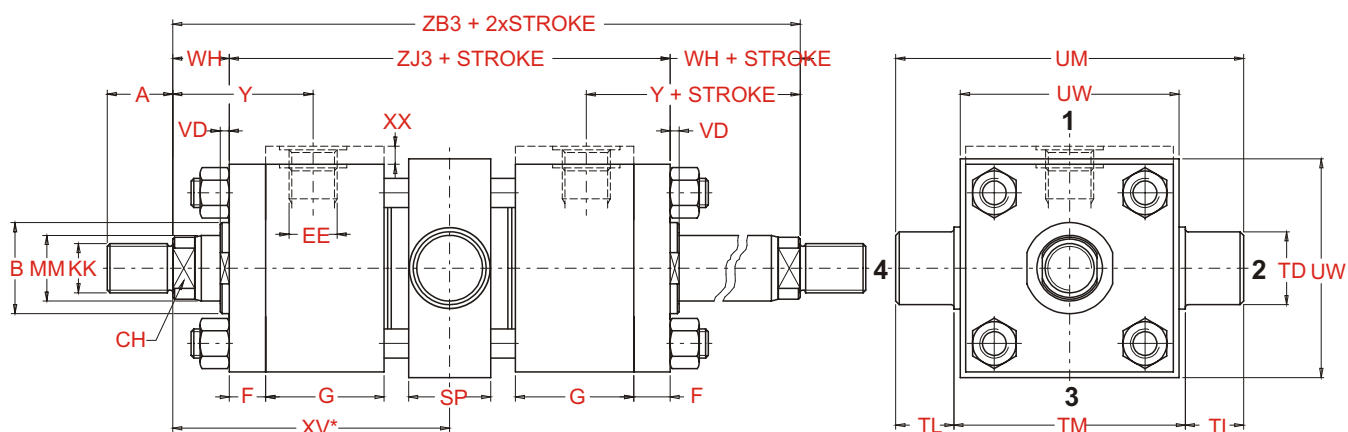

MM - Rod diameter

Bore	MM	A	B	CH	XX	F	G	EE	KK	SP	TD	TL	TM	UM	UW	VD	XV	XV+HOD	WH	Y	ZB3	ZJ3	HOD
Ø	Ø	max	f9					(BSP)	(Metric)	max	f8	h14	h15	max	max	min.	max.	± 2	± 2	± 2	± 1	min.	
25	12	14	24	9	5	10	45	1/4"	M 10x1,25	20	12	10	48	68	45	6	80	69	15	50	149	119	11
	18	18	30	14					M14x1,5														
32	14	16	26	11	5	10	45	1/4"	M12x1,25	25	16	12	55	79	50	12	93	79	25	60	172	122	13
	18	18	30	14					M14x1,5							6							
	22	22	34	17					M16x1,5							12							
40	18	18	30	14	-	10	55	3/8"	M14x1,5	30	20	16	76	108	70	6	105	93	25	62	198	148	12
	22	22	34	17					M16x1,5							12							
	28	28	42	22					M20x1,5							10							
	22	22	34	17					M16x1,5							7							
50	28	28	42	22	-	15	55	1/2"	M20x1,5	40	25	20	89	129	85	7	116	94	26	68	210	158	22
	36	36	50	30					M27x2							10							
	28	28	42	22					M20x1,5							7							
63	36	36	50	30	-	15	55	1/2"	M27x2	40	32	25	100	150	95	10	123	103	33	71	226	160	20
	45	45	60	36					M33x2							14							
	36	36	50	30					M27x2							5							
	45	45	60	36					M33x2							9							
80	45	45	60	36	-	20	65	3/4"	M33x2	45	40	32	127	191	120	9	139	115	31	77	254	192	23
	56	56	72	50					M42x2							9							
	45	45	60	36					M33x2							7							
100	56	56	72	50	-	22	69	3/4"	M42x2	60	50	40	140	220	130	7	156	118	35	82	274	204	38
	70	63	88	60					M48x2							10							
	56	56	72	50					M42x2							6							
	70	63	88	60					M48x2							10							
125	70	63	88	60	-	22	78	1"	M48x2	70	63	50	178	278	170	10	170	142	35	86	312	242	44
	90	85	108	75					M64x3							10							
	70	63	88	60					M48x2							7							
160	90	85	108	80	-	25	86	1"	M64x3	90	80	63	215	341	205	7	188	137	32	86	325	261	91
	110	95	133	100					M80x3							7							
	90	85	108	80					M64x3							7							
	90	85	108	80					M80x3							7							
200	110	95	133	100	-	25	103	1" 1/4	M80x3	110	100	80	279	439	275	7	215	164	32	98	379	315	51
	140	112	163	130					M100x3							7							
	110	95	133	100					M80x3							7							



## How to order a HYDROMAT A3 series cylinder compliant with ISO 6020/2

The HYDROMAT A3 series cylinders compliant with ISO 6020/2 standards are provided with an identification code which describes the construction specifications in a non-ambiguous way. To make up the code for the order, follow the code diagram set out below and insert the letters identifying the various features of the desired cylinder in the sequence given below.

Features	Description	Code
<b>Series</b>	To ISO 6020/2 standards To ISO 6020/2 standards with magnetic sensor <sup>1)</sup> To ISO 6020/2 stand. for taking lin. transducers <sup>2)</sup>	A3 M3 T3
<b>Bore</b>	Specify bore in mm (indicate 3 figures)	-
<b>Rod MM (diameter)</b>	12 mm (bore 25) 14 mm (bore 32) 18 mm (bore 25, 32 and 40) 22 mm (bore 32, 40 and 50) 28 mm (bore 40, 50 and 63) 36 mm (bore 50, 63 and 80) 45 mm (bore 63, 80 and 100) 56 mm (bore 80, 100 and 125) 70 mm (bore 100, 125 and 160) 90 mm (bore 125, 160 and 200) 110 mm (bore 160 and 200) 140 mm (bore 200)	A B D F H L M P R T V Z
<b>Stroke</b>	Specify the stroke in mm (indicate 4 figures)	-
<b>Rod type</b>	Without cushioning Front cushioning Rear cushioning Cushioning on both ends Double rod without cushioning Double rod with cushioning	C E G P S T
<b>Special machining of rod end</b>	Light male thread Female thread Light female thread Customised thread	x w y z
<b>Mounting type</b>	Basic version (not in line to ISO 6020/2) Rectangular front flange (not in line to ISO 6020/2) Rectangular rear flange (not in line to ISO 6020/2) Side foot (ISO MS2) Head trunnion (ISO MT1) Cap trunnion (ISO MT2) Intermediate fixed trunnion (ISO MT4) Rear clevis (ISO MP3) Rear spherical bearing (ISO MP5) Cap fixed clevis (IS MP1) Extended front tie rods (ISO MX3) Extended rear tie rods (ISO MX2) Extended on both ends tie rods (ISO MX1) Head flange (ISO ME5) Cap flange (ISO ME6) Front screwed tapped holes (ISO MX5) Rear screwed tapped holes (ISO MX6)	00 01 02 03 04 05 06 07 08 09 10 11 12 13 14 30 31

### Cylinder ordering code

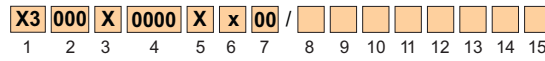

Omit if is not look for

Example of cylinder code:  
**A3063H0125E02**

**A3** = series differential Cylinder compliant with ISO 6020/2  
**063** = bore 63  
**H** = rod 28  
**125** = stroke 125  
**E** = front cushioning  
**02** = rectangular rear flange (not compliant with ISO standards).

The positions of the inlet connections and front cushion are standard so they are not specified in the order code (oil feeding inlets side 1 on head and cap - cushion side 3 on head

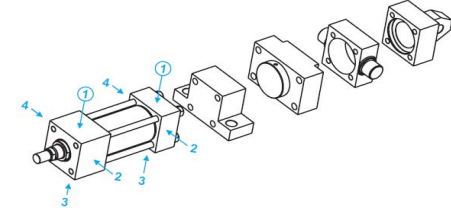

When issuing the order for the cylinder, provide the following information:

- code identifying the model
- quantity
- special features (if requested) with any enclosed sketches and/or construction drawings
- operating conditions for special uses
- delivery date with type of priority

Code	Description	Features
K00	Specify the position of the front and rear inductive sensors	<b>Position of inductive sensors</b>
S00	Specify the position of the front and rear air bleeds	<b>Position of air bleeds</b>
R00	Specify the position of the front and rear braking adjustment devices	<b>Position of braking adjustment devices</b>
P00	Specify the position of front and rear connections	<b>Position of connections</b>
-	Specify the number of spacers (multiples of 50 mm)	<b>Spacers</b>
T U <sup>3)</sup> V <sup>4)</sup>	Seals for water and glycol mixtures Low friction seals Seals for high temperatures and/or aggressive fluids	<b>Seals</b>
D <sup>5)</sup> E <sup>5)</sup> F <sup>5)</sup>	Front inductive sensor Rear inductive sensor Front and rear inductive sensor	<b>Inductive sensors</b>
A B C <sup>6)</sup>	Front air bleed Rear air bleed Front and rear air bleeds	<b>Air bleed</b>

<sup>3)</sup> Minimum working pressure: 20 bar  
<sup>4)</sup> Max. working temp. for M3, T3 and A3 series cylinders fitted with inductive sensors: 70 °C  
 Using inductive sensors, the cylinder must be provided with cushioning (front or rear)  
<sup>5)</sup> Not available for bores 25 and 32, see page 42  
<sup>6)</sup> Compulsory for T3 series cylinders

Example of cylinder code:  
**A3100M0400PW10/FUP14K22**

**A3** = series differential Cylinder compliant with ISO 6020/2 standards  
**100** = bore 100, **M** = rod 45, **0400** = stroke 400,  
**P** = cushioning on both ends,  
**W** = female thread rod ends  
**10** = extended front tie rods (ISO Mx3)  
**F** = front and rear inductive sensor, **U** = low friction seals  
**P** = position of incoming connections side 1 on the head and side 4 on the cap  
**K** = position of inductive sensor side 2 on head and 2 on cap

<sup>1)</sup> Not available for bores 160 and 200, see page 40  
<sup>2)</sup> Not available for bores 25, 32, 40 (rods 18 and 22), 50 (rod 22), see page 43

- standard cushion position side 3 on head and cap (see Table 19 on page 64).