

Rear self aligning clevis

MP5

Type 08

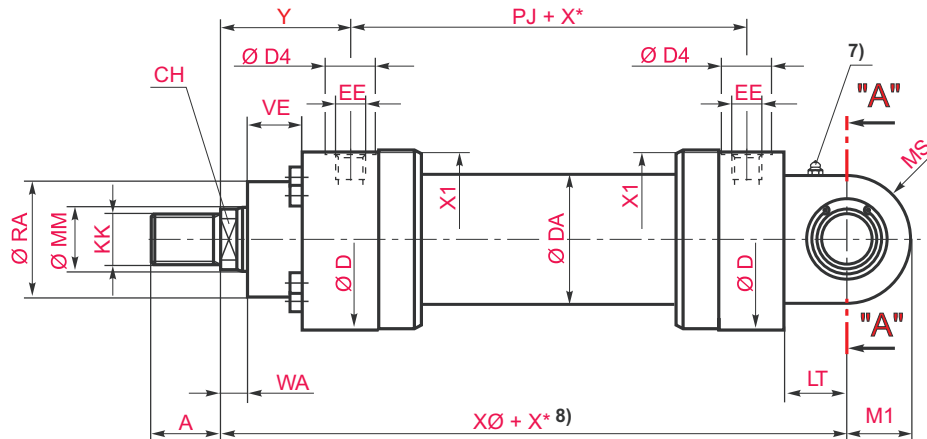
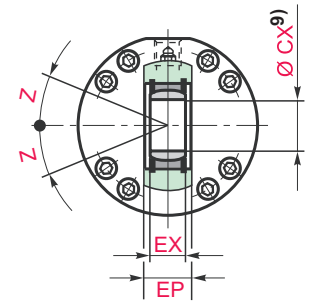

Piston Ø	MM	A 5)	KK 5)	A 6)	KK 6)	CH	D <sub>max</sub>	DA	D4 2)	EE 4)	EE 4)	Y	PJ
40	22 / 28	16	M 16x1.5	30	M 18x2	16 / 22	88	50	34	G 1/2	M 22x1.5	79	120
50	28 / 36	22	M 22x1.5	35	M 24x2	22 / 30	102	60	34	G 1/2	M 22x1.5	87	120
63	36 / 45	28	M 28x1.5	45	M 30x2	30 / 36	120	78	42	G 3/4	M 27x2	100	133
80	45 / 56	35	M 35x1.5	55	M 39x3	36 / 46	140	95	42	G 3/4	M 27x2	104	146
100	56 / 70	45	M 45x1.5	75	M 50x3	46 / 60	170	125	47	G 1	M 33x2	124	171
125	70 / 90	58	M 58x1.5	95	M 64x3	60 / 75	206	150	58	G 1 1/4	M 42x2	135	205
140	90 / 100	65	M 65x1.5	110	M 80x3	75 / 85	226	170	58	G 1 1/4	M 42x2	156	219
160	100 / 110	80	M 80x2	120	M 90x3	85 / 95	265	190	65	G 1 1/2	M 48x2	185	240
180	110 / 125	100	M 100x2	140	M 100x3	95 / 110	292	210	65	G 1 1/2	M 48x2	199	264
200	125 / 140	110	M 110x2	150	M 110x4	110 / 120	310	235	65	G 1 1/2	M 48x2	205	278
220	140 / 160	120	M 120x3	160	M 120x4	120/140	355	273	65	G 1 1/2	M 48x2	242	326
250	160 / 180	120	M 120x3	160	M 120x4	140/160	393	305	65	G 1 1/2	M 48x2	266	326
280	180 / 200	130	M 130x3	190	M 150x4	160/180	425	343	65	G 1 1/2	M 48x2	282	375
320	200 / 220	-	-	200	M 160x4	180/200	490	394	65	G 1 1/2	M 48x2	287	431

Piston Ø	MM Ø	X1	WA	XO	X* min	LT	M1	MS	CX	EP -0,4	EX	Z	RA f8	VE
40	22 / 28	41	14	252	-	32,5	28	31	25 <sub>0,010</sub>	23	20 <sub>0,12</sub>	7°	52	40
50	28 / 36	48,5	18	265	-	37,5	32,5	36	30 <sub>0,010</sub>	28	22 <sub>0,12</sub>	6°	65	40
63	36 / 45	56,5	22	302	-	45	40	42	35 <sub>0,012</sub>	30	25 <sub>0,12</sub>	6°	75	45
80	45 / 56	67	20	330	-	50	50	52	40 <sub>0,012</sub>	35	28 <sub>0,12</sub>	7°	95	45
100	56 / 70	82	30	385	-	60	62,5	65	50 <sub>0,012</sub>	40	35 <sub>0,12</sub>	6°	115	55
125	70 / 90	99	32	447	-	70	70	70	60 <sub>0,015</sub>	50	44 <sub>0,15</sub>	6°	135	60
140	90 / 100	109,5	35	490	-	75	82	82	70 <sub>0,015</sub>	55	49 <sub>0,15</sub>	6°	155	70
160	100 / 110	129	40	550	-	85	95	95	80 <sub>0,015</sub>	60	55 <sub>0,15</sub>	6°	200	80
180	110 / 125	142,5	40	610	-	90	113	113	90 <sub>0,020</sub>	65	60 <sub>0,20</sub>	5°	220	90
200	125 / 140	152	40	645	-	115	125	125	100 <sub>0,020</sub>	70	70 <sub>0,20</sub>	7°	235	95
220	140 / 160	174	40	750	-	125	142,5	132,5	110 <sub>0,020</sub>	80	70 <sub>0,20</sub>	6°	270	115
250	160 / 180	194	40	789	-	140	160	150	110 <sub>0,020</sub>	80	70 <sub>0,20</sub>	6°	300	125
280	180 / 200	210	40	884	31	150	180	170	120 <sub>0,020</sub>	90	85 <sub>0,20</sub>	6°	325	130
320	200 / 220	242	40	980	-	175	200	190	140 <sub>0,020</sub>	110	90 <sub>0,020</sub>	7°	365	155

\* Unless otherwise specified, all dimensions are given in millimetres.

MM = Piston rod Ø

X\* = Stroke length

1) = Bleeding: When viewed on the piston rod, the orientation is always offset by 90° to the pipe connection (in a clockwise direction)

2) = Ø D4 max. 0,5 mm deep

3) = Throttle valve only with end position damping „E” (180° to the bleed point)

4) = For flange connections see separate table on pages 17

5) = Thread version „G”

6) = Thread version „A”

7) = Grease nipple; cone head form A to DIN 71412

8) = Take the minimum stroke length „X\*min.” into account

9) = Associated pin Ø m6; associated pin Ø j6 with maintenance-free self-aligning clevis



## How to order a HYDROMAT H1 series cylinder compliant with ISO 3320

The HYDROMAT H1 series cylinders compliant with ISO 3320 standards are provided with an identification code which describes the construction specifications in a non-ambiguous way. To make up the code for the order, follow the code diagram set out below and insert the letters identifying the various features of the desired cylinder in the sequence given below.

Features	Description	Code
Series	To ISO 3320 standards	H1
	To ISO 3320 standards for taking transducer	T1
Bore	Specify bore in mm (indicate 3 figures)	-
Rod MM (diameter)	22 mm (bore 40)	F
	28 mm (bore 40 and 50)	H
	36 mm (bore 50 and 63)	L
	45 mm (bore 63 and 80)	M
	56 mm (bore 80 and 100)	P
	70 mm (bore 100 and 125)	R
	90 mm (bore 125 and 140)	T
	100 mm (bore 140 and 160)	U
	110 mm (bores 160 and 180 <sup>5)</sup> )	V
	125 mm (bores 180 <sup>5)</sup> and 200)	A
	140 mm (bore 200 and 220)	Z
	160 mm (bore 220 and 250)	B
180 mm (bore 250 and 280)	X	
200 mm (bore 280 and 320)	C	
220 mm (bore 320)	Y	
Stroke	Specify the stroke in mm (indicate 4 figures)	-
Rod type	Without cushioning	C
	Front cushioning	E
	Rear cushioning <sup>6)</sup>	G
	Cushioning on both ends <sup>6)</sup>	P
	Double rod without cushioning	S
Double rod with cushioning	T	
Special machining	Female rod threading	w
	Customised machining	z
Mounting type	Side foot (not in line to ISO 3320)	03
	Intermediate fixed trunnion (ISO MT4)	06
	Rear clevis (ISO MP3)	07
	Rear spherical bearing (ISO MP5)	08
	Front flange (ISO MF3)	13
Rear flange (ISO MF4)	14	

5) Bore non-compliant with ISO 3320 standard  
6) Not available for bores 50 and 63 of the T1 series

### Cylinder ordering code

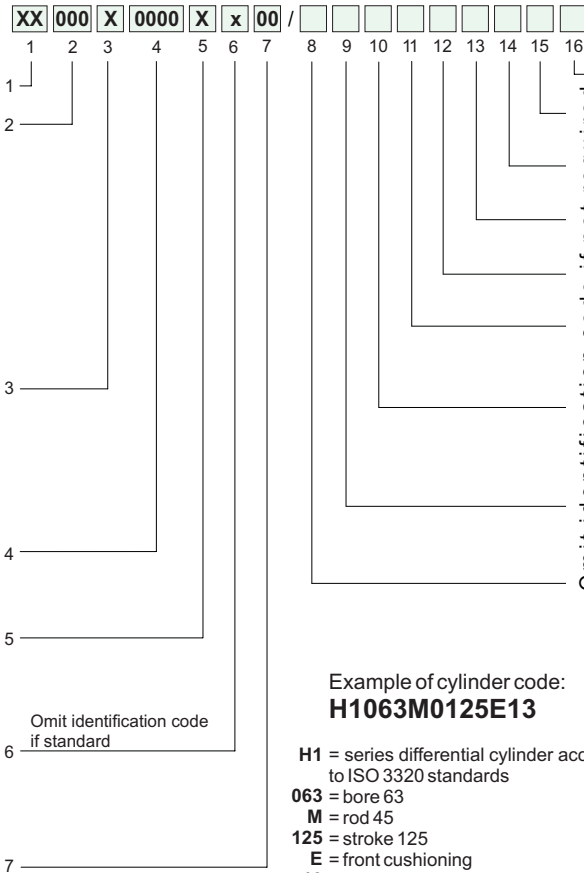

Example of cylinder code:  
**H1063M0125E13**

- H1 = series differential cylinder according to ISO 3320 standards
- 063 = bore 63
- M = rod 45
- 125 = stroke 125
- E = front cushioning
- 13 = front flange (ISO MF3)

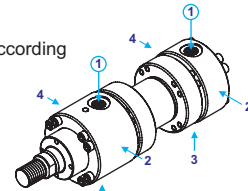

The input connection and front cushioning positions are standard so they are not specified in the ordering code (oil feeding inlets side 1 on head and cap, cushioning side 3 on head as specified in Table 13. on page 43).

- When issuing the order for the cylinder, provide the following information:
- code identifying the model
  - quantity
  - special features (if requested) with any enclosed sketches and/or construction drawings
  - operating conditions for special uses
  - delivery date with type of priority

Code	Description	Features
D	Specify the position of the drainage connection	Drainage connection
K	Specify the position of the front and rear inductive sensors	Position of inductive sensors
S	Specify the position of the front and rear air bleeds	Position of air bleeds
R	Specify the position of the front and rear braking adjustment devices	Position of braking adjustment devices
P	Specify the position of front and rear connections	Position of connections
-	Specify the number of spacers (multiples of 50 mm)	Spacers
T U <sup>1)</sup> V <sup>2)</sup> Z	Seals for water and glycol mixtures Low friction seals Seals for high temperatures and/or aggressive fluids Seals for heavy applications	Seals
D <sup>3)</sup> E <sup>3)</sup> F <sup>3)</sup>	Front inductive sensor Rear inductive sensor Front and rear inductive sensor	Inductive sensors
A B C <sup>4)</sup>	Front air bleed Rear air bleed Front and rear air bleeds	Air bleeds

1) min. working pressure 20 bar  
2) max. working temperature for T1 and H1 series cylinders fitted with inductive sensors: 70 °C  
3) Using inductive sensors, the cylinder must be provided with cushioning (front or rear)  
4) Compulsory for T1 series cylinders

Example of cylinder code:  
**H1125T0800PW06 / FU P14 K22**

- H1 = series differential cylinder to ISO 3320 standards
- 125 = bore 125, T = rod 90, 0800 = stroke 800
- P = cushioning on both ends
- W = female rod threading
- 06 = intermediate fixed trunnion (ISO MT4)
- F = front and rear inductive sensor
- U = low friction seals
- P = position of input connections side 1 on head and side 4 on cap
- K = position of inductive sensor side 2 on head and cap

Cushioning in standard position side 3 on head and cap (see Table 13. on page 43).