

Njihajuće pričvršćenje - centralno -

MT4

Tip 06

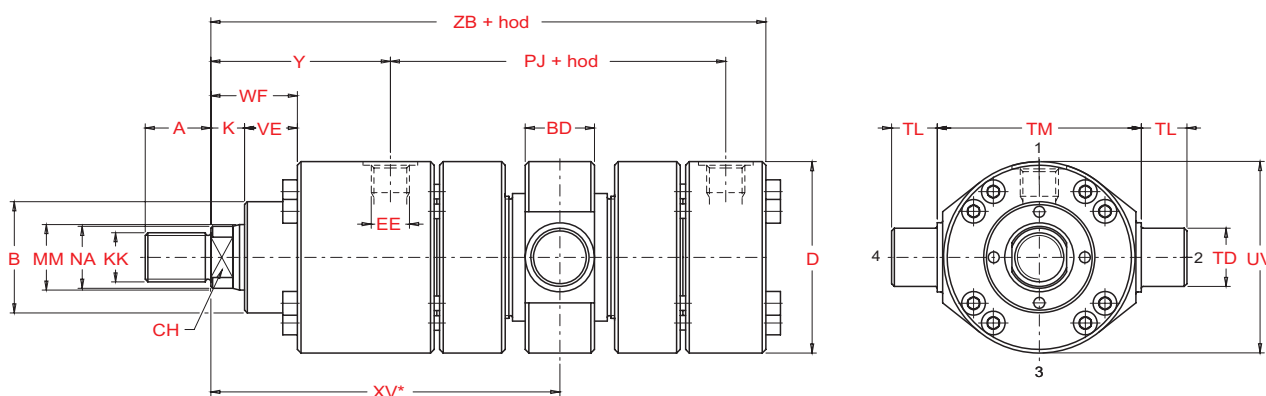
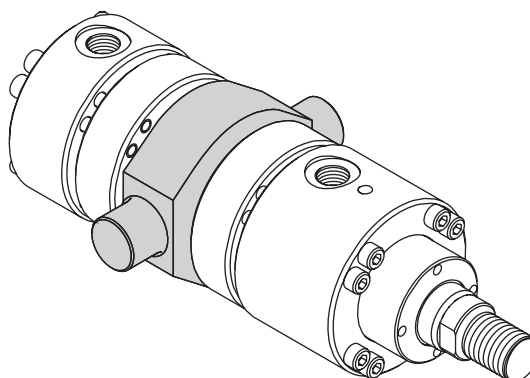

MM - promjer klipnjače

Klip Ø	MM Ø	A	B ⁸ Ø	CH	D _{max} Ø	EE (BSP)	KK (Metric)	NA Ø	K	VE	WF	BD	TD ⁸ Ø	TL	TM ^{h13}	UV Ø	XV mini.	XV+stroke max.	Y	PJ	ZB _{max}	stroke mini.
50	32	36	63	28	105	1/2"	M27x2	31	18	29	47	38	32	25	112	105	180	144	98	120	244	45
	36		32	35																		
63	40	45	75	34	122	3/4"	M33x2	38	21	32	53	48	40	32	125	122	195	160	112	133	274	45
	45			36				43														
80	50	56	90	43	145	3/4"	M42x2	48	24	36	60	58	50	40	150	145	220	175	120	155	305	60
	56			46				54														
100	63	63	110	53	175	1"	M48x2	60	27	41	68	73	63	50	180	175	245	185	134	171	340	80
	70			60				67														
125	80	85	132	65	210	1"	M64x3	77	31	45	76	88	80	63	224	210	290	220	153	205	396	95
	90			75				87														
140 ⁵⁾	90	90	145	75	255	1" 1/4	M72x3	87	31	45	76	98	90	70	265	255	330	240	181	208	430	115
	100			85				96														
160	100	95	160	85	270	1" 1/4	M80x3	96	35	50	85	108	100	80	280	270	340	255	185	235	467	115
	110			95				106														
180 ⁵⁾	110	105	185	95	315	1" 1/4	M90x3	106	40	55	95	118	110	90	320	315	390	270	205	250	505	150
	125			-				121														
200	125	112	200	-	330	1" 1/4	M100x3	121	40	61	101	133	125	100	335	330	430	280	220	278	550	180
	140			-				136														
250	160	125	250	-	410	1" 1/2	M125x4	155	42	71	113	180	160	125	425	410	505	320	260	325	652	220
	180			-				175														
320	200	160	320	-	510	2"	M160x4	195	48	88	136	220	200	160	530	510	590	380	310	350	764	260
	220			-				214														
400	250	200	400	-	628	2"	M200x4	242	53	110	163	270	250	200	630	628	630	340	310	355	775	340
	280			-				270														

5) Promjer klipa nije prema standardu ISO 6022

* U slučaju narudžbe navedite dimenzije

Ako nije drugačije naznačeno sve dimenzije su u milimetrima.

