

Pričvršćenja na stopama - dvostrana klipnjača (pričvršćenje nije prema standardu ISO)

MS2

Tip 03

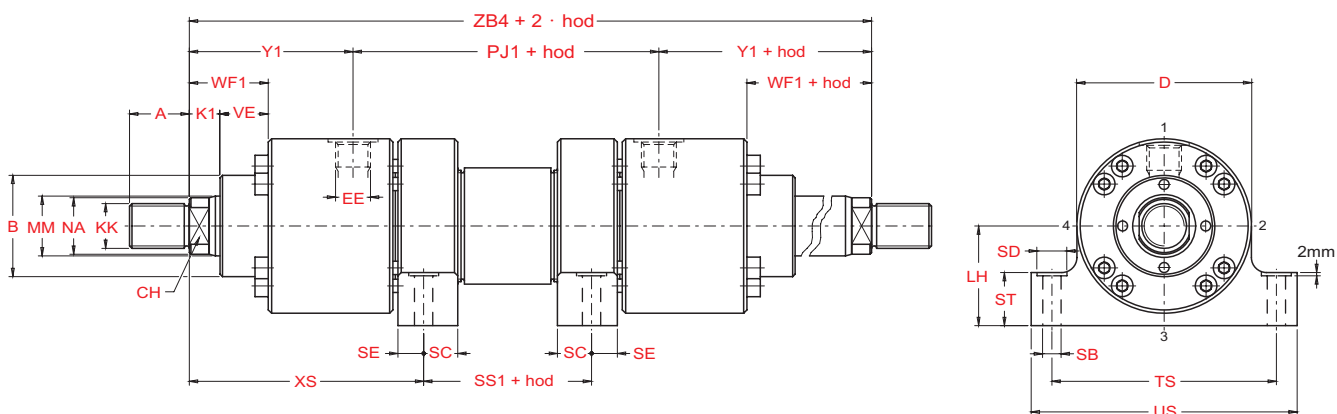
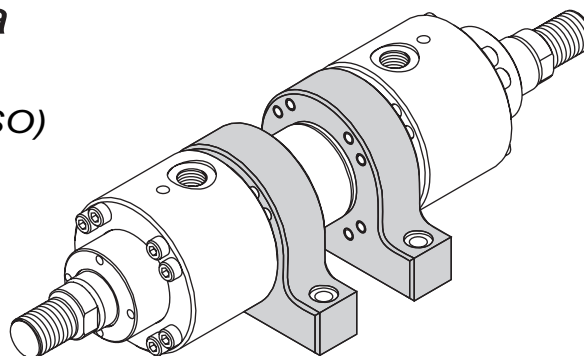

MM - promjer klipnjače

Klip Ø	MM Ø	A	B ^B Ø	CH	D _{max} Ø	EE (BSP)	KK (Metric)	NA Ø	K1	VE	WF1	LH ^{h10}	SB ^{h13} Ø	SD Ø	SC	SE	ST	TS	US	XS	Y1	SS1	PJ1	ZB4
50	32	36	63	28	105	1/2"	M27x2	31	18	29	47	60	11	18	20,5*	16	32	135	160	130	98	62	126	322
	36			35																				
63	40	45	75	34	122	3/4"	M33x2	38	19	32	51	68	13,5	20	24,5*	18	37	155	185	148	110	59	134	354
	45			43																				
80	50	56	90	43	145	3/4"	M42x2	48	24	36	60	80	17,5	26	22,5	23	42	185	225	171	120	53	153	393
	56			54																				
100	63	63	110	53	175	1"	M48x2	60	27	41	68	95	22	33	27,5	28	52	220	265	193	134	48	165	433
	70			67																				
125	80	85	132	65	210	1"	M64x3	77	31	45	76	115	26	40	30	30	62	270	325	230	153	50	204	510
	90			87																				
140 ⁵⁾	90	90	145	75	255	1" 1/4	M72x3	87	31	45	76	135	30	48	35,5	36	77	325	390	255	181	61	208	570
	100			96																				
160	100	95	160	85	270	1" 1/4	M80x3	96	38	50	88	145	33	48	37,5	38	77	340	405	266	188	70	225	601
	110			106																				
180 ⁵⁾	110	105	185	95	315	1" 1/4	M90x3	106	40	55	95	165	40	60	42,5	43	87	390	465	288	205	85	250	660
	125			121																				
200	125	112	200	-	330	1" 1/4	M100x3	121	40	61	101	170	40	60	47*	45	87	405	480	315	220	81	271	711
	140			136																				
250	160	125	250	-	410	1" 1/2	M125x4	155	48	71	119	215	52	76	52*	50	112	520	620	360	266	120	308	840
	180			175																				
320	200	160	320	-	510	2"	M160x4	195	48	88	136	260	62	110	62*	60	152	620	740	425	310	120	350	970
	220			214																				
400	250	200	400	-	628	2"	M200x4	242	53	110	163	320	80	120	75	75	170	760	900	455	310	91	355	975
	280			270																				

5) Promjer klipa nije prema standardu ISO 6022

* Rupe za pričvršćenje nisu u sredini pričvršne stope.

Ako nije drugačije naznačeno sve dimenzije su u milimetrima.

